



JOCT101Xh-L4 Series

Rev.A.1.0

DESCRIPTION:

s

t Ä

Junction Temperature	T_j	135	
Storage Temperature	T_{stg}	-55~+125	
Soldering Temperature	T_{sol}	260	

NOTE1: μ

NOTE2

ELECTRICAL CHARACTERISTICS (Temperature=25°C)

Parameter		Symbol	Condition	Min.	Typ.	Max.	Unit
Input	Forward Voltage	V_F	$I_F=10mA$	-	1.2	1.5	V
	Reverse Current	I_R	$V_R=6V$	-	-	1	μA
	Terminal Capacitance	C_t	$V=0, f=1MHz$	-	30	250	pF
	Collector-Emitter dark current	I_{CEO}	$V_{CE}=20V, I_F=0$	-	-	50	nA
Output	Collector-Emitter breakdown voltage	BV_{CEO}	$I_C=0.1mA, I_F=0$	80	-	-	V
	Emitter-Collector breakdown voltage	BV_{ECO}	$I_E=0.1mA, I_F=0$	7	-	-	V
	Current transfer ratio	CTR	$I_F=5mA, V_{CE}=5V$	80	-	600	%

Transfer
Characteristics

ORDERING INFORMATION

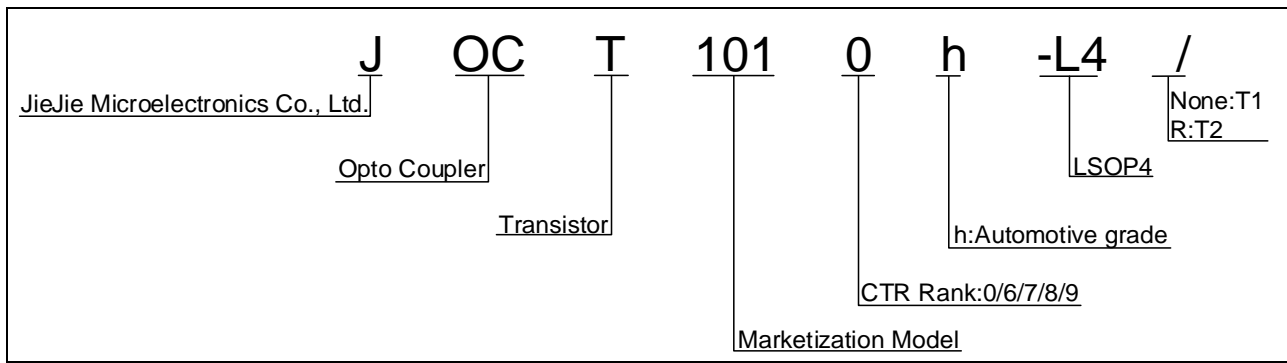

Packing Quantity	
Option	Quantity

MARKING

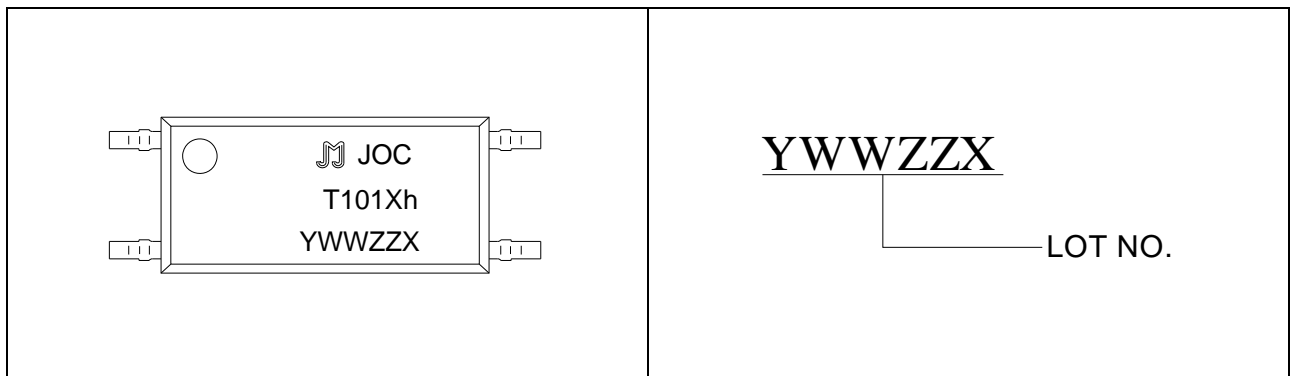

Characteristics Curves

FIG.1: Max. Allowable LED Forward Current vs. Ambient Temperature

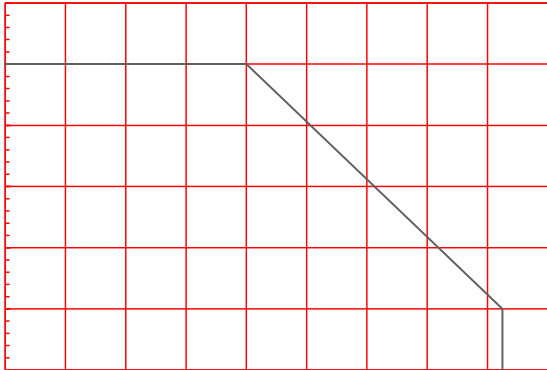

FIG.2: Collector Power Dissipation vs. Ambient Temperature

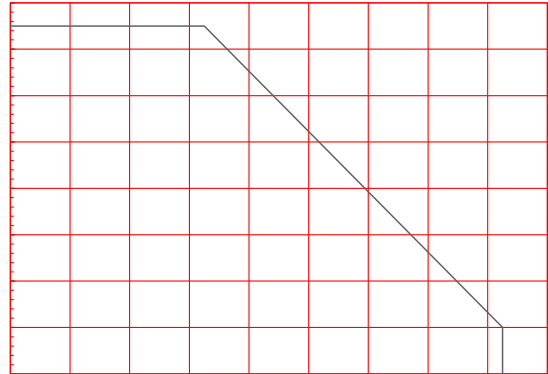

FIG.3: Forward Current vs. Forward Voltage

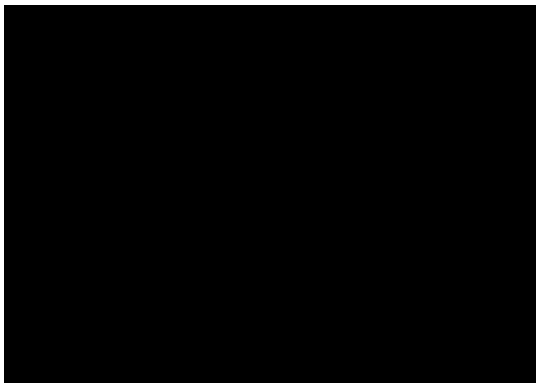
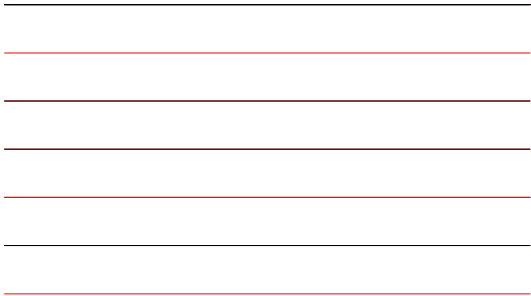

FIG.4: Normalized Collector Dark Current vs. Ambient Temperature

FIG.7: Normalized Current Transfer Ratio vs. Ambient Temperature

FIG.8: Normalized Collector-emitter Saturation Voltage vs. Ambient Temperature



Test Circuits

FIG.11: Test Circuits of Response Time

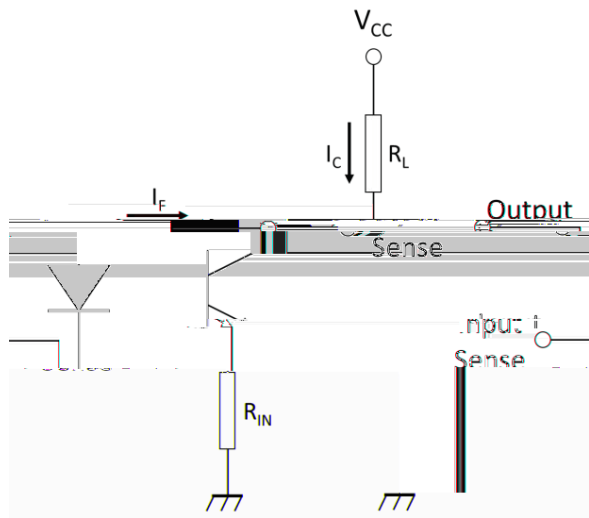

FIG.12: Curves of Response Time

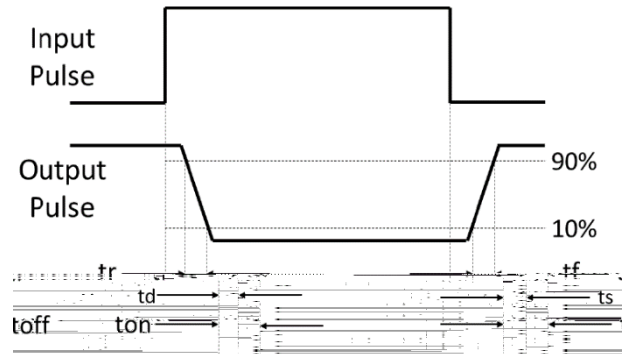
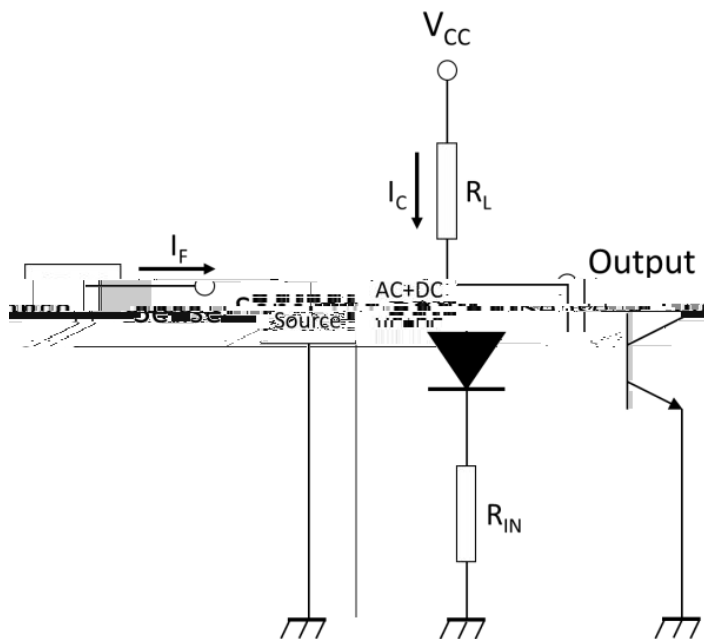

FIG.13: Test Circuits of Frequency Response



Package Dimension (Unit: mm)

Ref.	Dimensions	
	Millimeters	Inches

REFLOW INFORMATION

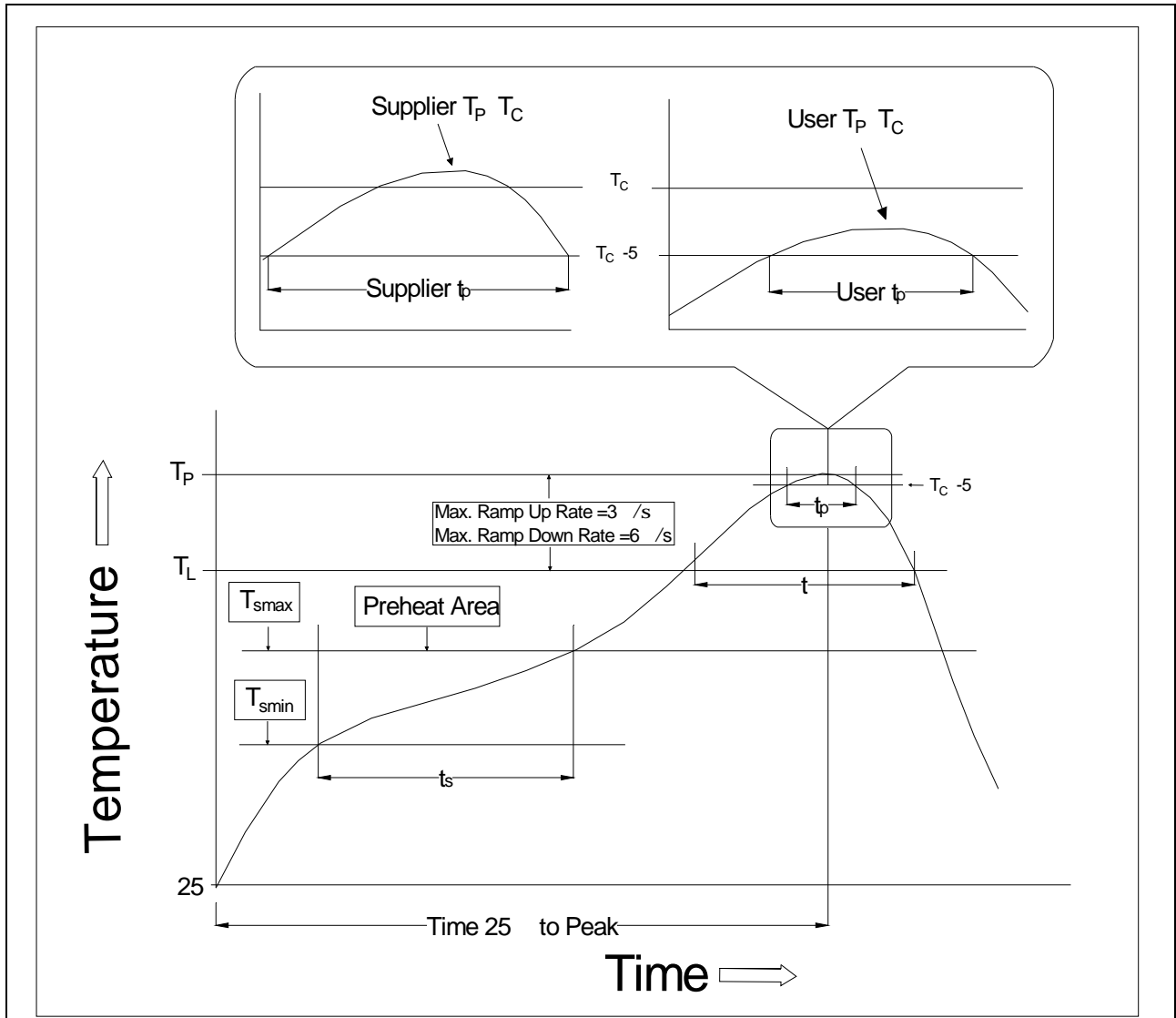

Profile Feature	Sn-Pb Assembly Profile	Pb-Free Assembly Profile
Temperature Min. (T _{min})	100	150
Temperature Max. (T _{smax})	150	200
Time (t _s) from (T _{smin} to T _{smax})	60-120 seconds	60-120 seconds
Ramp-up Rate (t _L to t _P)	3 °C/second max.	3 °C/second max.
Liquidus Temperature (T _L)	183	217
Time (t _L) Maintained Above (T _L)	60-150 seconds	60-150 seconds
Peak Body Package Temperature	235 +0 /-5	260 +0 /-5
Time (t _P) within 5 °C of 260	20 seconds	30 seconds
Ramp-down Rate (T _P to T _L)	6 °C/second max.	6 °C/second max.
Time 25 °C to Peak Temperature	6 minutes max.	8 minutes max.

Note:

1. Reflow soldering is recommended at the temperatures and times shown, no more than three times.
2. Avoid direct contact between the epoxy body and any tools or surfaces exceeding its maximum storage temperature.
3. Application of pressure on the epoxy body is prohibited at elevated temperatures. In specific scenarios, any applied force must not exceed 2.5N.
4. Ensure the component has cooled to ambient temperature before proceeding with any subsequent manufacturing steps.
5. The component has a shelf life of one year when stored under standard conditions.
6. Recommend storage Temp.: 0~40°C;
Recommend storage humidity: <60%;
MSL level: MSL 1

Information furnished in this document is believed to be accurate and reliable. However, Jiangsu JieJie Microelectronics Co., Ltd. assumes no responsibility for the consequences of use without consideration for such information nor use beyond it. Information mentioned in this document is subject to change without notice, apart from that when an agreement is signed, Jiangsu JieJie complies with the agreement.

Products and information provided in this document have no infringement of patents. Jiangsu JieJie assumes no responsibility for any infringement of other rights of third parties which may result from the use of such products and information. This document supersedes and replaces all information previously supplied.

 is a registered trademark of Jiangsu JieJie Microelectronics Co., Ltd.

Copyright © 2026 Jiangsu JieJie Microelectronics Co., Ltd. All rights reserved.