



Isolation Voltage	V_{iso}	5000	Vrms
Operating Temperature	T_{opr}	-40~110	
Junction Temperature	T_j	125	
Storage Temperature	T_{stg}	-40~125	
Soldering Temperature	T_{sol}	260	
Peak pulse voltage ($T_j=25$; non-repetitive,off-state)	V_{pp}	3	kV

NOTE1: 100 μ s pulse, 100Hz frequency

NOTE2: AC for 1minute, R.H.=40~60%

ELECTRICAL CHARACTERISTICS (Temperature=25°C)

Parameter		Symbol	Condition	Min.	Typ.	Max.	Unit
Input	Forward Voltage	V_F	$I_F=10mA$	-	1.2	1.5	V
	Reverse Current	I_R	$V_R=6V$	-	-	1	μA

Peak Off-state
Current, Either
Direction

I_{DRM1}
Direction

=

Output

ORDERING INFORMATION

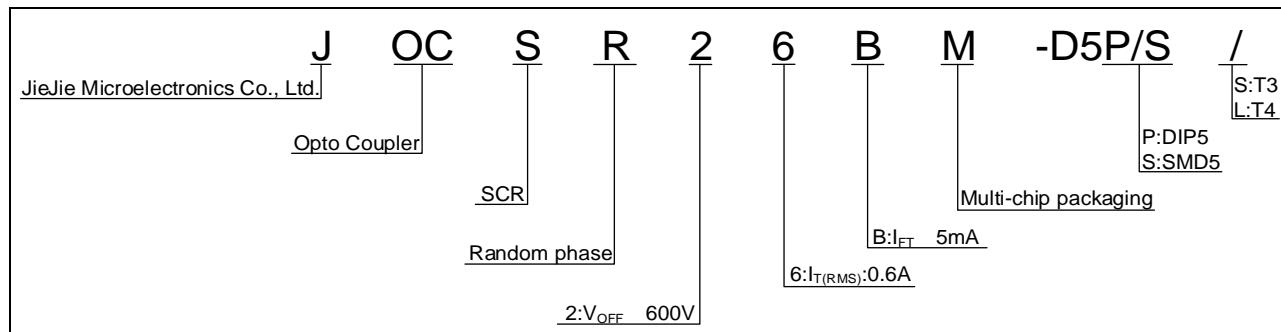

Packing Quantity	
Option	Quantity
DIP	60 Units/Tube
SMD	1200 Units/Reel

MARKING

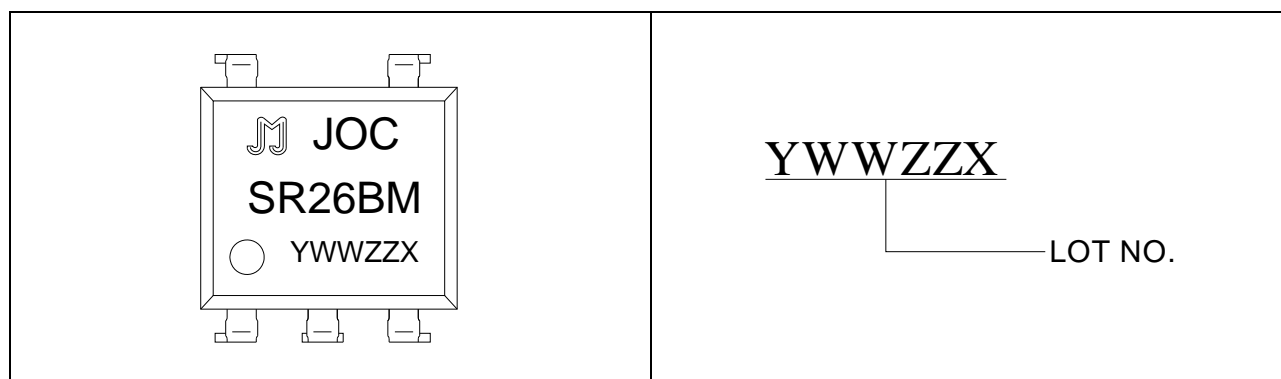

Characteristics Curves

FIG.1: Max. Allowable LED Forward Current vs. Ambient Temperature



FIG.2: On-state Terminal Current vs. Ambient Temperature

FIG.7: On-state characteristics

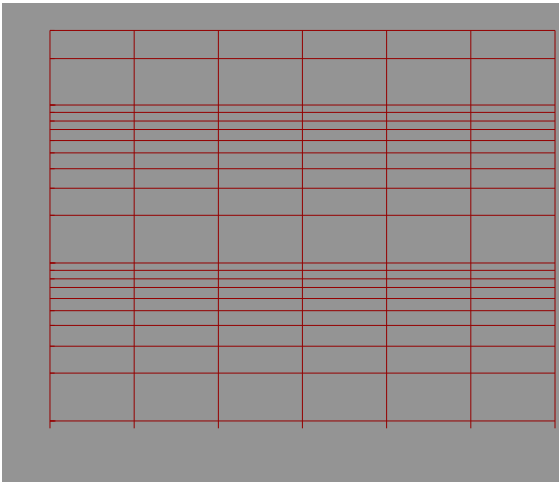

FIG.8: Normalized Holding Current vs. Ambient Temperature

TEST CIRCUITS

FIG.10: Test Circuits of Turn On Time

FIG.11: Waveforms of Turn On Time

FIG.12: Test circuit for inductive and resistive loads to IEC-61000-4-5 standards

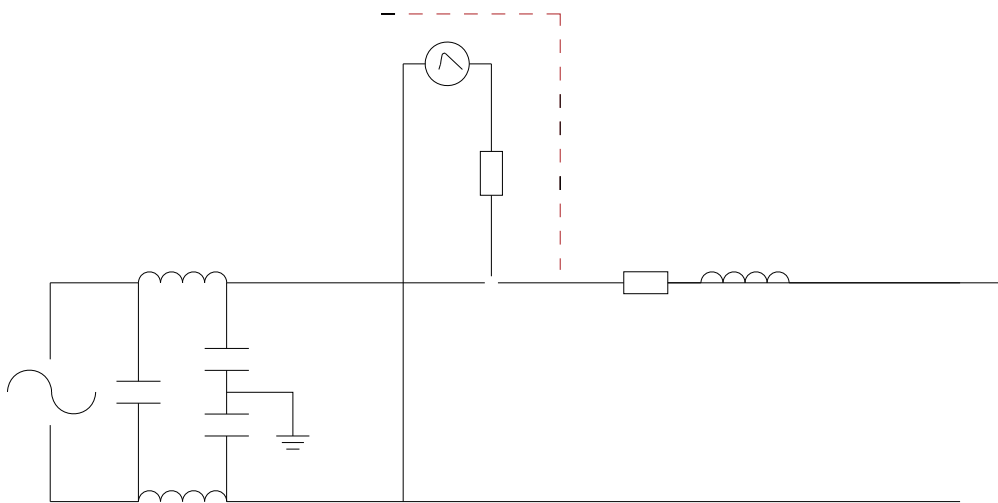



Package Dimension (Unit: mm)

Package Type: Dimensions Ref. Typ. Max. Min. Typ. Max. 244 EGIK6.206.600.

RECOMMENDED SOLDER MASK (Dimensions in mm unless otherwise stated)

Option SMD

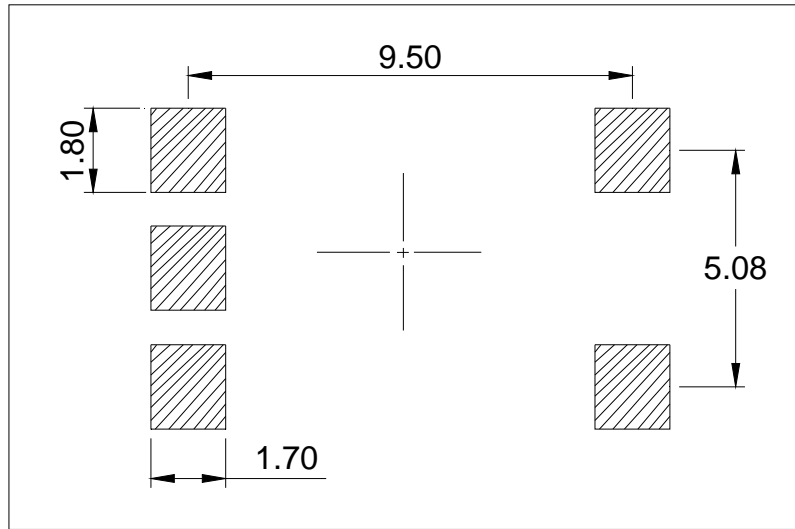

TUBE SPECIFICATIONS (Dimensions in mm unless otherwise stated)

Standard DIP

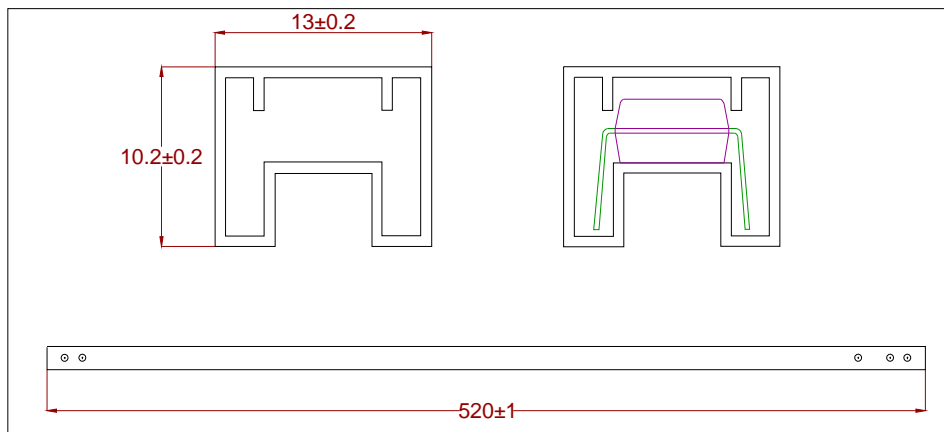

CARRIER TAPE SPECIFICATIONS (Dimensions in mm unless otherwise stated)

Option S/L

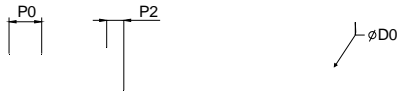

Ref.	Dimensions					
	Millimeters			Inches		
	Min.	Typ.	Max.	Min.	Typ.	Max.
D0		1.50	1.60		0.059	0.063
P0	3.90	4.00	4.10	0.154	0.157	0.161
P1	11.90	12.00	12.10	0.469	0.472	0.476
P2	1.90	2.00	2.10	0.075	0.079	0.083
E	1.65	1.75	1.85	0.065	0.069	0.073
F	7.40	7.50	7.60	0.291	0.295	0.299
T	0.35	0.40	0.45	0.014	0.016	0.018
W	15.70	16.00	16.30	0.618	0.630	0.642

REFLOW INFORMATION

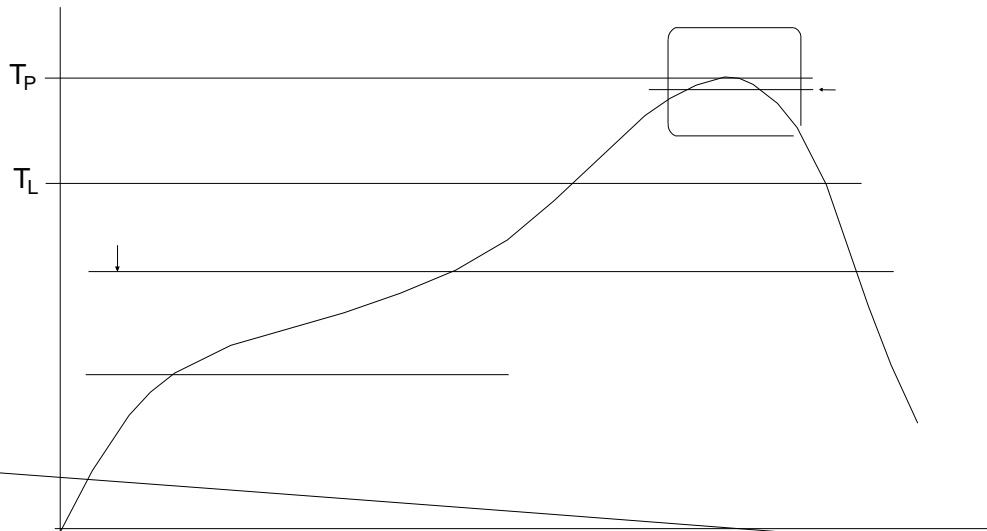
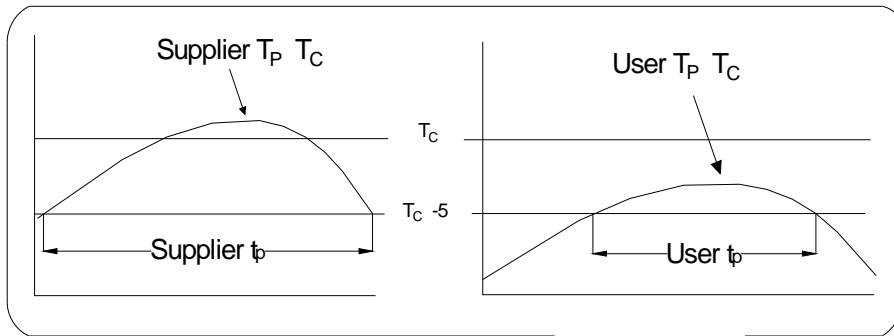

WAVE SOLDERING

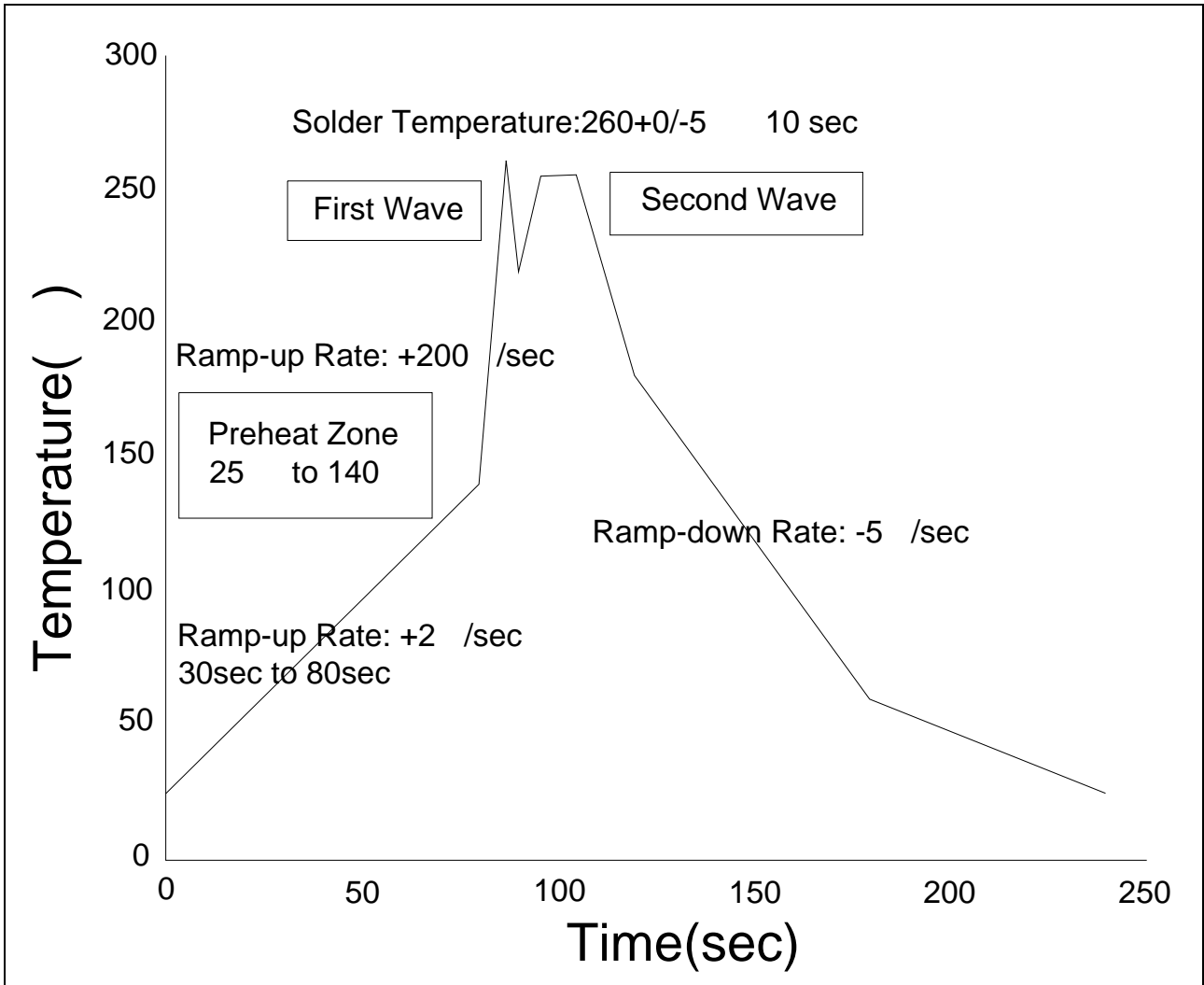

HAND SOLDERING BY SOLDERING IRON

Soldering Temperature	360± 5
Soldering Time	3s max.

Note:

1. Reflow soldering is recommended at the temperatures and times shown, no more than three times.
2. Avoid direct contact between the epoxy body and any tools or surfaces exceeding its maximum storage temperature.
3. Application of pressure on the epoxy body is prohibited at elevated temperatures. In specific scenarios, any applied force must not exceed 2.5N.
4. Ensure the component has cooled to ambient temperature before proceeding with any subsequent manufacturing steps.
5. The component has a shelf life of one year when stored under1

q u p M N o e a t a