

### DESCRIPTION:

The JOC308XD4 series combine an AlGaAs infrared emitting diode as the emitter which is optically coupled to a monolithic silicon zero-cross photo triac in a plastic DIP4 package with different lead forming options. The products are widely used

3 0 Td 3nsteoliel Tc 0 Tw ( )Tj -/004 Tc -0.002 Tw 0.33 05Td [(wi)-10vusyvusiaits Tc 0 Tw ( )Tj 672 [

	Power Dissipation Derating ( $T_a$ 125 )	$\bullet P_{D/}$	-3.33	mW/
Total Power Dissipation		$P_{tot}$	350	mW
Isolation Voltage		$V_{iso}$	5000'	Vrms
Operating Temperature		$T_{opr}$	-55~100	
Storage Temperature		$T_{stg}$	-55~125	
Soldering Temperature		$T_{sol}$	260 <sup>8</sup>	

NOTE1AC for 1minute, R.H.=40~60%

NOTE2For 10 seconds

ELECTRICAL CHARACTERISTICS (T<sub>J</sub> 0 T<sub>c</sub> 0 T<sub>w</sub> 1.43 0 T<sub>d</sub> ( ) T<sub>j</sub> EMC /P <</MCID 50

ORDERING AND MARKING INFORMATION

MARKING INFORMATION

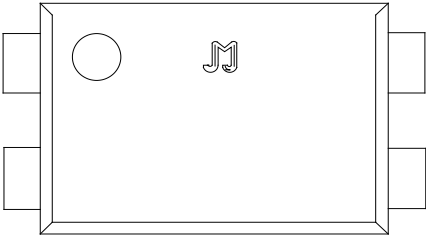

## Characteristics Curves

FIG.1: Forward Current vs. Ambient Temperature

FIG.2: On-state Terminal Current vs. Ambient Temperature

FIG.7: Normalized On-state Terminal Voltage vs. Ambient Temperature



FIG.8: On-state Terminal Voltage vs. On-state Terminal Current

TEST CIRCUITS

FIG.12: Test Circuits of Turn On Time

FIG.13: Waveforms of Turn On Time

Fig.14: Test Circuits of dV/dt

Fig.15: Waveforms of dV/dt



Option S Type:

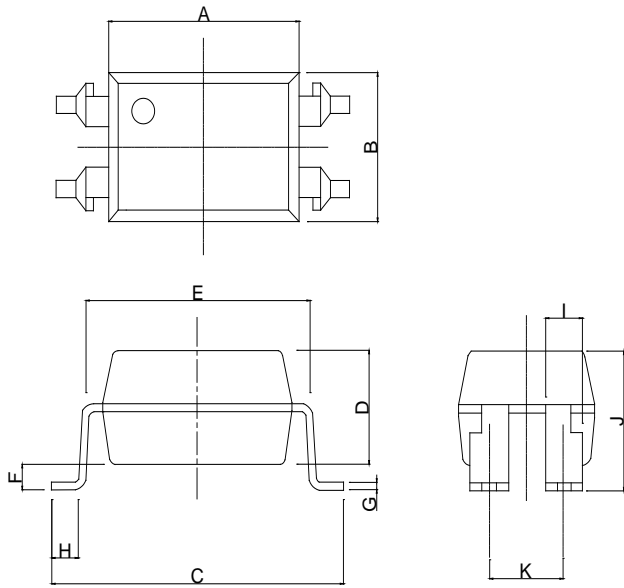

Ref.	Dimensions					
	Millimeters			Inches		
	Min.	Typ.	Max.	Min.	Typ.	Max.
A	6.30		6.70	0.249		0.265
B	4.38		4.78	0.173		0.189
C	9.85		10.45	0.389		0.413
D	3.30		3.70	0.130		0.146
E	7.32		7.92	0.289		0.313
F		0.80			0.032	
G		0.25			0.010	
H		0.80			0.032	
I	1.20		1.40	0.047		0.055
J	4.00		4.60	0.158		0.182
K		2.54			0.100	

Option SL Type:

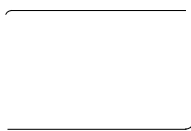

Option S LM Type:

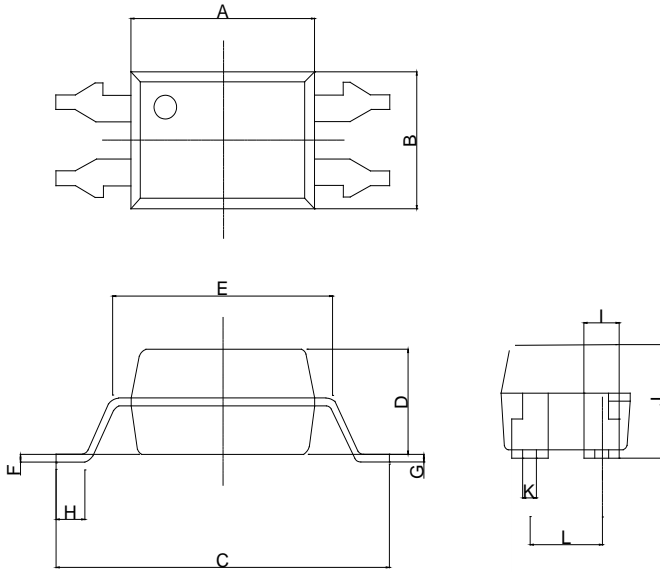

Ref.	Dimensions					
	Millimeters			Inches		
	Min.	Typ.	Max.	Min.	Typ.	Max.
A	6.30		6.70	0.248		0.264
B	4.38		4.78	0.172		0.188
C	11.50		12.10	0.453		0.476
D	3.30		3.70	0.130		0.146
E	7.32		7.92	0.288		0.312
F						
G						
H	0.40			0.016		
I	1.20		1.40	0.047		0.055
J	3.45		4.05	0.136		0.159
K						
L						



TUBE SPECIFICATIONS (Dimensions in mm unless otherwise stated)

Standard DIP

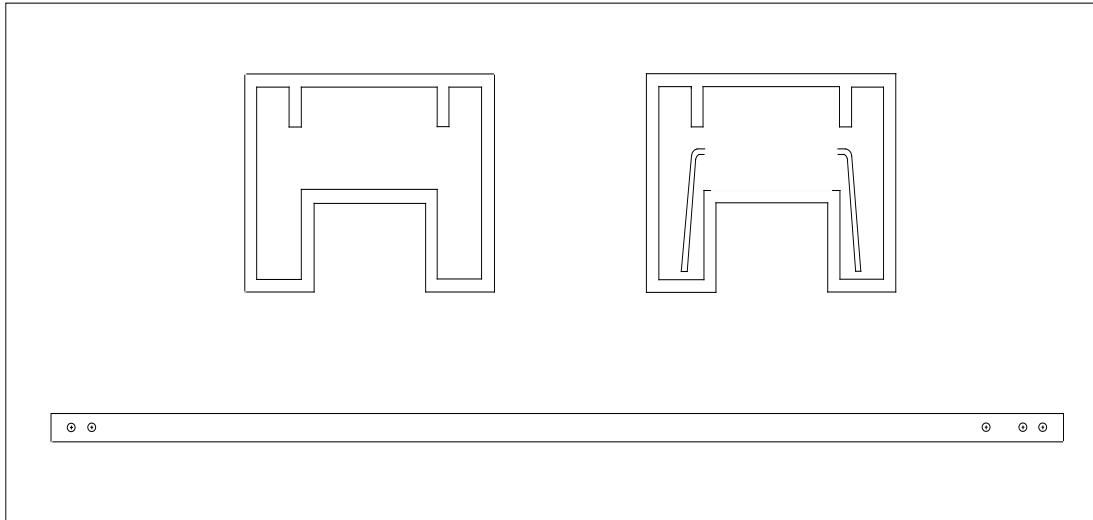

Option M

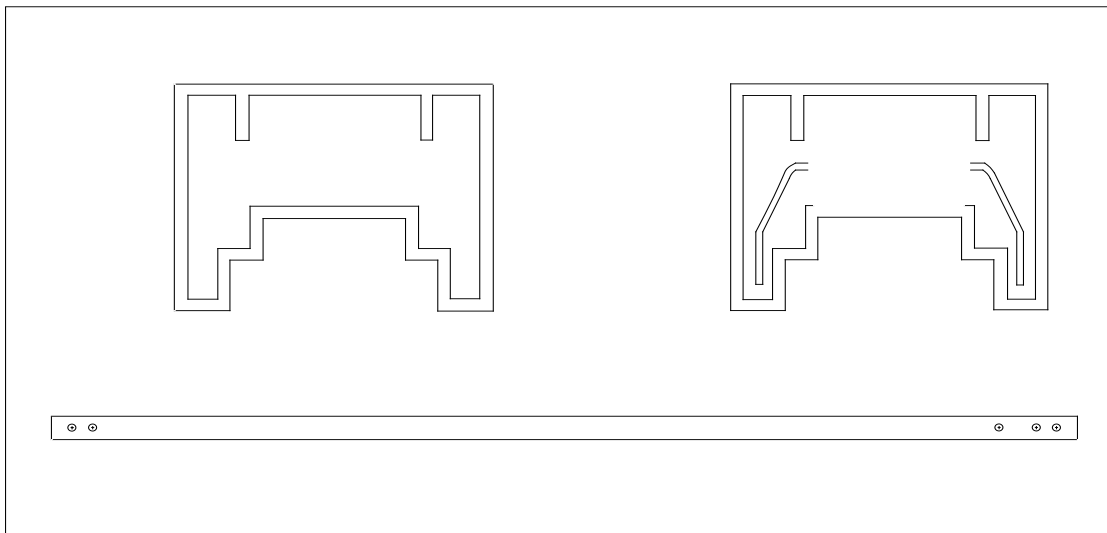



Option SL(T3)

Ref.	Dimensions					
	Millimeters			Inches		
	Min.	Typ.	Max.	Min.	Typ.	Max.
D0						
P0						
P1		12.00			0.472	
P2						
E		1.75			0.069	
F		7.50				
T		0.40			0.016	
W		16.00			0.630	

REFLOW INFORMATION

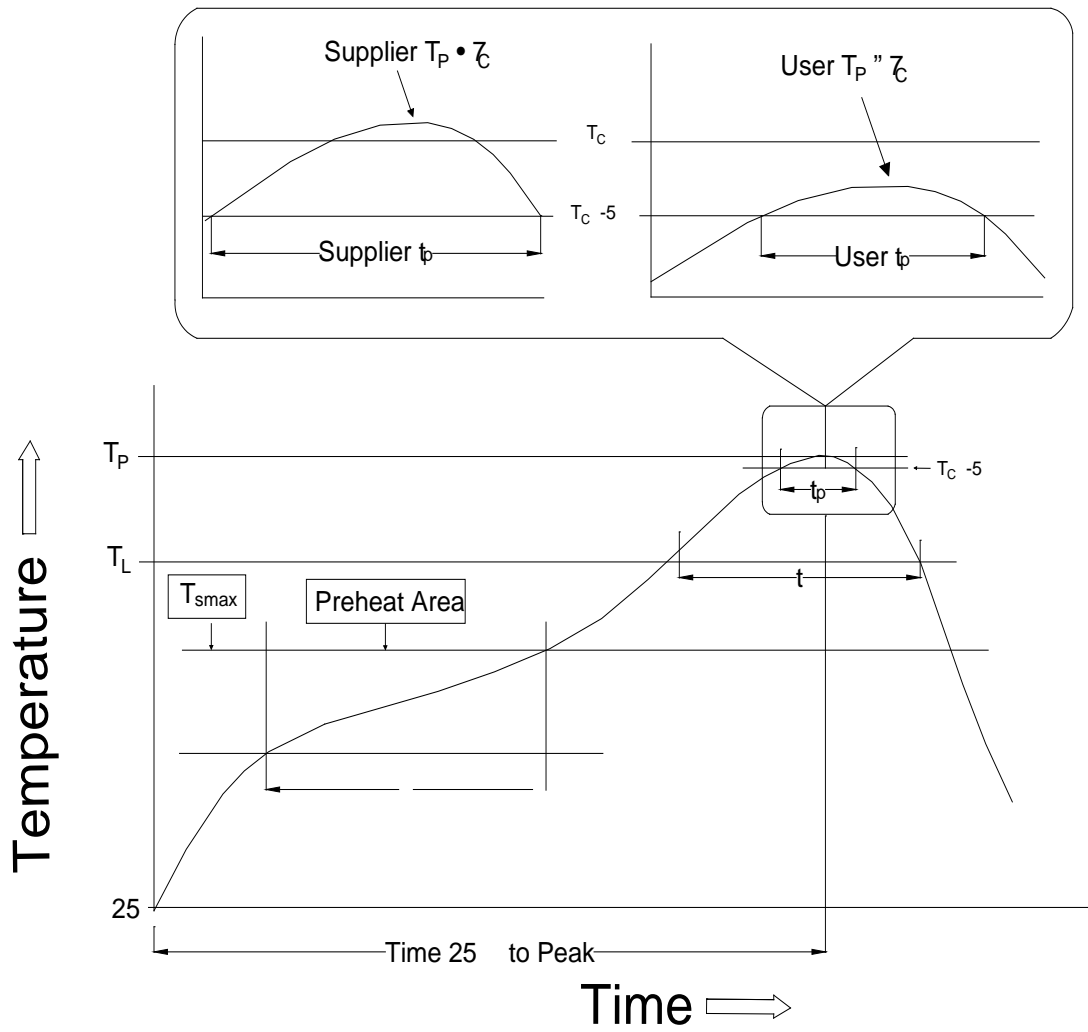

## WAVE SOLDERING

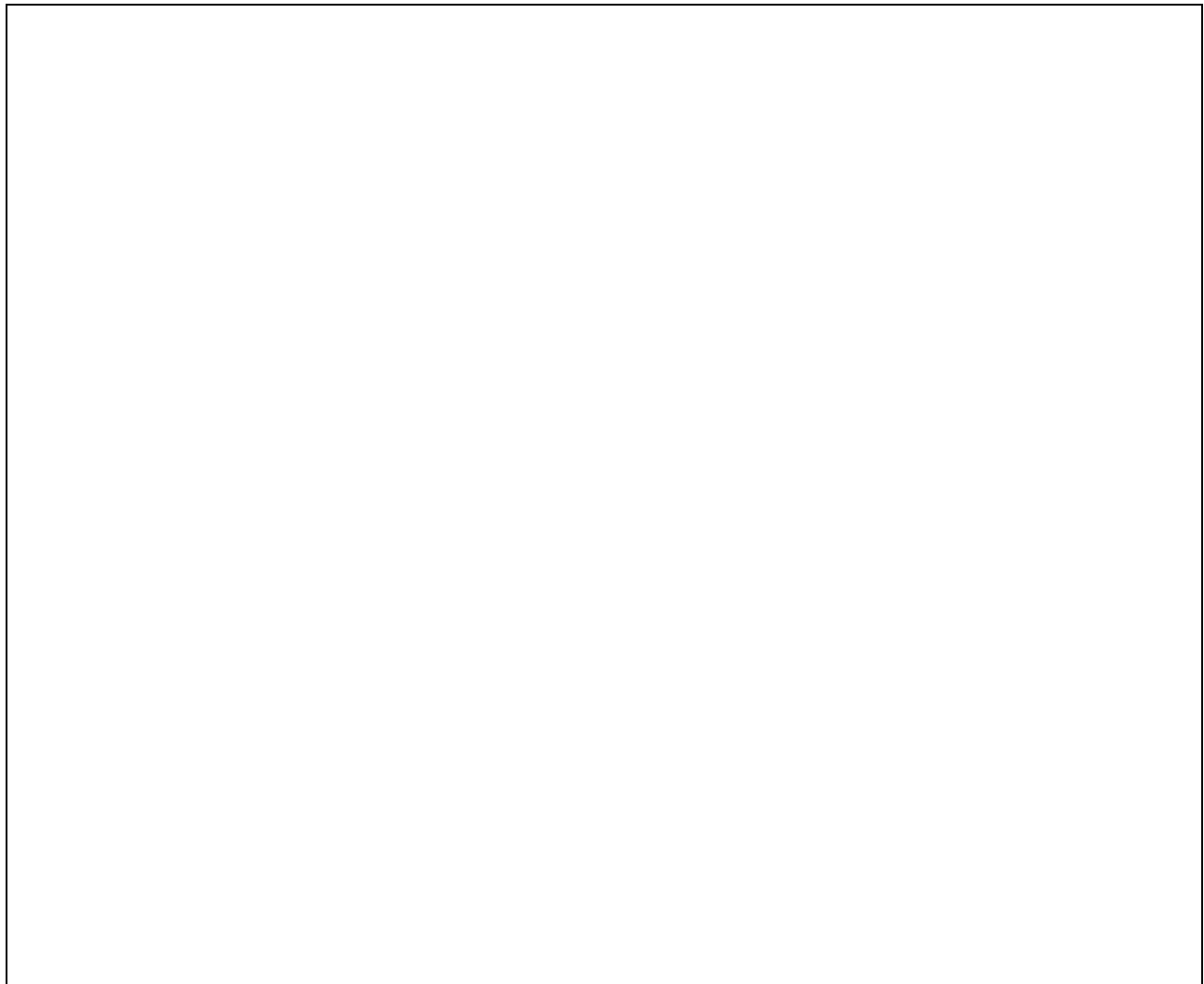

## HAND SOLDERING BY SOLDERING IRON

Soldering Temperature	360 5
Soldering Time	3s max.

## Document Revision History

Date	Revision	Changes
Apr.2, 2025	A.1.0	Last update
Nov.5, 2025	A.1.1	Add SLM package

Information furnished in this document is believed to be accurate and reliable. However, Jiangsu JieJie Microelectronics Co., Ltd. assumes no responsibility for the consequences of use without consideration for such information nor use beyond it. Information mentioned in this document is subject to change without notice, apart from that when an agreement is signed, Jiangsu JieJie complies with the agreement.

Products and information provided in this document have no infringement of patents.